

SANY[®]

SPECIFICATION



 70t

 47.5m

 64m

STC700T5

SANY TRUCK CRANE

QUALITY CHANGES THE WORLD

www.sanyglobal.com

V1.1

It is one of the core business units in SANY Group, specializing in the development and manufacturing of high-end wheel cranes, crawler cranes and tower cranes, including the complete range of wheel cranes from 8 to 2400t, crawler cranes from 25 to 4500t and tower cranes from 6 to 185t.

三一集团旗下核心事业部，从事高端轮式起重机、履带起重机、塔式起重机系列产品的研发制造。覆盖8-2400吨全吨位轮式起重机，25-4500吨全吨位履带起重机，6-185吨塔式起重机。



SANY CRANE



SANY TRUCK CRANE STC700T5 / 70T LIFTING CAPACITY

Excellent load capacity

性能卓越

47.5m full-extension 5-section large U-shape profile boom, 16m jib, max. lifting height 64m and max. lifting moment 2303kN.m.

5 节臂, 大截面 U 型主臂, 主臂全长 47.5m, 副臂全长 16m,
最大起吊高度 64m, 最大起重力矩达 2303kN.m。





Double pump intelligent flow distribution system

双泵智能流量分配系统

Adopt stable and high quality oil pump, motor and motor, the min. winch single rope speed is less than 1.5m/min, the min. stable slewing speed is less than 0.1°/s, easy to realize mm-level high precision operation.

New double pump intelligent flow distribution system, independent luffing, confluent telescoping, combined motion stability increased by more than 50%.

The electro-hydraulic control system can save 15% energy and also improve the efficiency of heavy load operation by 30%.

采用稳定、高品质的油泵、马达，卷扬单绳最低速度小于 1.5m/min，回转最低稳定小于 0.1°/s，轻松实现毫米级吊装。

全新开发双泵智能流量分配系统，变幅独立，伸臂合流，复合动作平稳性提升 50% 以上。电液复合系统使上车吊载综合节能 15%，重载作业效率提升 30%。

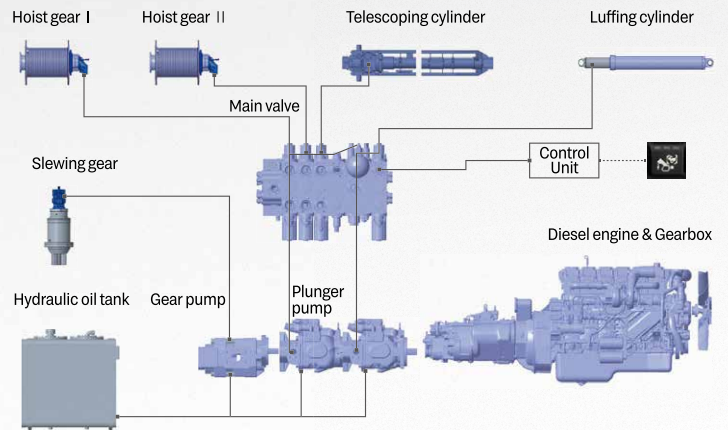

Strong bearing chassis

高承载能力底盘

Brand new 2.8m wide chassis, high-strength rectangular crosssection frame, improving torsion and bending resistance. DF Cummins high quality engine, 10-speed FAST transmission with emergency steering, HANDE heavy-duty double-reduction axle, the max. gradeability of 45%, fuel consumption 40L per 100 km. 385 large-size steel wire tires, ground clearance > 310mm with good accessibility.

Equipped with 400L large volume fuel reservoir, endurance is close to 1000km.

高承载 2.8m 宽体底盘，高强矩形截面车架，吊载抗弯、抗扭能力强。

东康高品质发动机，法士特 10 档变速箱带应急转向，汉德高承载双减桥。

最大爬坡度 45%，百公里综合油耗 40L。

385 高承载钢丝胎，离地间隙 > 310mm，通过性好。

配置 400L 大容积燃油箱，续航接近 1000km。



i-Cab - Driver's cab

新两室 - 下车

Multi-function seat with air suspension, making driving more comfortable.

Double seats and foldable berth for the co-driver.

12.1-inch LCD screen integrated with back-up image and multi-media.

Electric rearview mirror with electric heating, ensuring good field of view in foul weather.

Adjustable high-brightness LED headlamps/fog lamps, providing clear vision at night.

Reversing sensor with accurate distance detection capability, fully covering the parking area without blind spots, and effectively avoiding scratch and collision.

Full-automatic HVAC, able to automatically adjust indoor temperature as demanded.

主驾驶位配备气浮多功能座椅, 驾驶更舒适。

副驾驶位设置双座椅可折叠式卧铺。

12.1 寸液晶触摸大显示屏, 集成倒车影像、语音娱乐功能。

电动、电加热后视镜, 不惧怕恶劣冰雪天气。

高亮度可调节 LED 大灯 / 雾灯, 提供夜间清晰视野。

倒车雷达, 探头后方无死角, 精准探距, 防碰防撞。

全自动冷暖空调, 自动根据需求调整室内温度。



SANY TRUCK CRANE STC700T5 / 70T LIFTING CAPACITY



i-Cab - Operator's cab

新两室 - 上车

Seat widened to 480mm, and leg room increased by 30%. Cab tiltable by 0-20°, relieving cervical fatigue during large-angle and long-boom operations. Adjustable seat with maximum inclination of 140°, allowing the operator to lie flat and rest after work. Functional panel and left & right armrest motion panels arranged modularly, easy to reach and operate. 70° openable front window convenient for ventilation and escape. Curved-track sliding door, more convenient for getting on/off the cab and opening/closing the door. Full-automatic HVAC, able to automatically adjust indoor temperature as demanded.

座椅加宽至 480mm,腿部活动空间较上一代增加 30%。
操纵室可实现 0-20° 上仰变位,在大角度、长臂段作业时减缓颈椎疲劳。
可调式座椅,最大后仰 140°,让操作手可以平躺休息。
配备功能面板及左右扶手箱动作按键面板,触手可及,方便操控。
70° 可开启式前窗,方便通风及逃生。
变轨滑移门,上下车、开关门更方便。
全自动冷暖空调,自动根据需求调整室内温度。



Overall Dimensions

整机尺寸

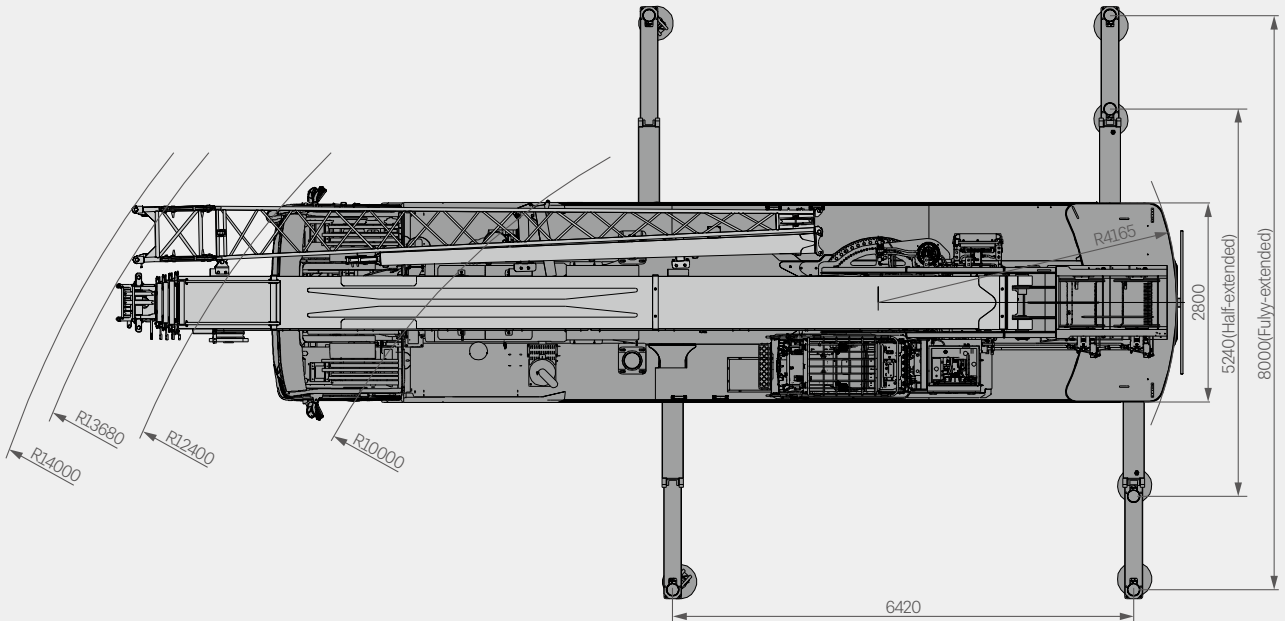
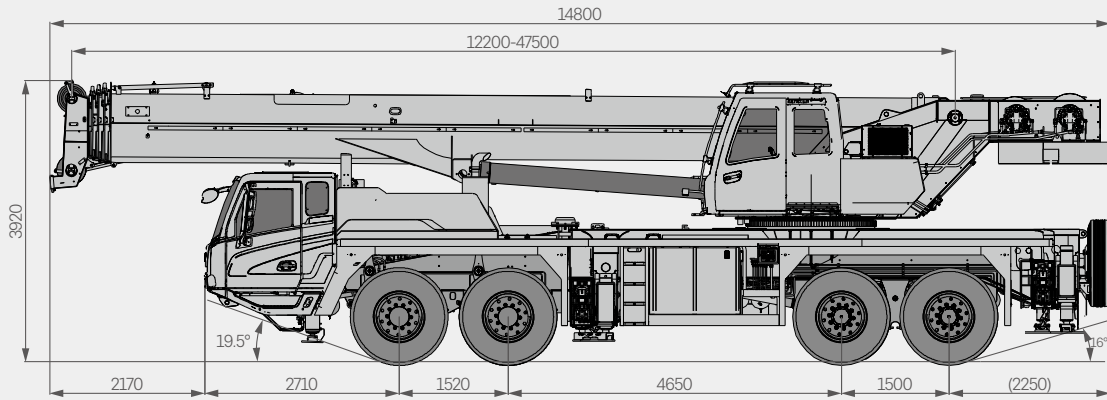

Technical Specification

整机参数

CATEGORY 类型	ITEM 项目	UNIT 单位	VALUE 参数	
CAPACITY 额定起重量	Max. lifting capacity 最大起重量	t	70	
WEIGHT 重量	Gross weight 整机总质量	kg	44200	
POWER (CHASSIS) 发动机参数 (下车)	Engine model 发动机型号 (排放标准)	-	DF Cummins ISLe340 30 (Euro III) 东康 ISLe340 30(欧三)	
	Max. engine power 发动机最大功率	kW/rpm	250/2100	
	Max. engine torque 发动机最大输出扭矩	N·m/rpm	1425/1100~1400	
DIMENSIONS 尺寸参数	Overall length 整机全长	mm	14800	
	Overall width 整机全宽	mm	2800	
	Overall height 整机全高	mm	3920	
TRAVEL 行驶参数	Max. travel speed 最高行驶速度	km/h	85	
	Steering radius 转弯半径	Min. steering radius 最小转弯半径	m	10
		Min. steering radius of boom tip 臂头最小转弯半径	m	14
	Wheel formula 车轮模式	-	8 × 4 × 8	
	Min. ground clearance 最小离地间隙	mm	310	
	Approach angle 接近角	°	19.5	
	Departure angle 离去角	°	16	
	Max. gradeability 最大爬坡度	-	45	
	Fuel consumption per 100km 每 100 公里油耗	L	40	
	MAIN PERFORMANCE 主要性能参数	Working temperature range 使用温度区间	°C	-20~+45
Min. rated lifting radius 最小额定幅度		m	3	
Tail slewing radius 转台尾部回转半径		m	4.165	
Boom sections (Qty.) 臂节数		-	5	
Boom shape 臂形状		-	U shape U 型	
Max. lifting moment 最大起重力矩		Basic boom 基本臂	kN·m	2303
		Full-extension boom 全伸主臂	kN·m	1411
		Full-extension boom + jib 全伸主臂 + 副臂	kN·m	730
Boom length 臂长		Basic boom 基本臂	m	12.2
		Full-extension boom 全伸主臂	m	47.5
		Full-extension boom + jib 全伸主臂 + 副臂	m	63.5
Max. lifting height 最大起重高度		Basic boom 基本臂	m	12.7
		Full-extension boom 全伸主臂	m	48
		Full-extension boom + jib 全伸主臂 + 副臂	m	64
Outrigger span (Longitudinal × Transverse) 支腿跨距 (纵 × 横)		m	6.42 × 8.0	
Jib offset 副臂安装角度	°	0, 15, 30		
AIRCONDITIONER 空调	In operator's cab 上车空调	-	Heating & Cooling 制冷、制热	
	In driver's cab 下车空调	-	Heating & Cooling 制冷、制热	

Technical Specification

整机参数



Axle Load 轴荷

Axle 轴	1	2	3	4	Gross weight 总重量	Max. travel speed 车速限制/(km/h)
Axle load 轴荷/kg	10100	10100	12000	12000	44200	≤85
Remark 备注	With spare tire, main hook (on frame center). 带备胎, 主钩中置。					
Axle 轴	1	2	3	4	Gross weight 总重量	Max. travel speed 车速限制/(km/h)
Axle load 轴荷/kg	13250	13250	11100	11100	48700	≤50
Remark 备注	With spare tire, main hook (in front of the driver's cab), 4.5t movable counterweight (on frame center). 带备胎, 主钩前置, 带4.5t活配(中置)。					
Axle 轴	1	2	3	4	Gross weight 总重量	Max. travel speed 车速限制/(km/h)
Axle load 轴荷/kg	10600	10600	13750	13750	48700	≤40
Remark 备注	With spare tire, main hook (on frame center), 4.5t movable counterweight (on turntable tail). 带备胎, 主钩中置, 带4.5t活配(后置)。					
Axle 轴	1	2	3	4	Gross weight 总重量	Max. travel speed 车速限制/(km/h)
Axle load 轴荷/kg	13850	13850	12750	12750	53200	≤40
Remark 备注	With spare tire, main hook (in front of the driver's cab), 4.5t movable counterweight × 2 (one block on frame center, and another on turntable tail). 带备胎, 主钩前置, 带9t活配(一中一后)。					
Axle 轴	1	2	3	4	Gross weight 总重量	Max. travel speed 车速限制/(km/h)
Axle load 轴荷/kg	11400	11400	15200	15200	53200	≤25
Remark 备注	With spare tire, main hook (on frame center), 4.5t movable counterweight × 2 (on turntable tail). 带备胎, 主钩中置, 带9t活配(后置)。					



Hook 吊钩

Rated load 额载/t	Number of sheaves 滑轮数量	Rope rate 倍率	Hook weight/kg 吊钩重量
60	6	12	550
6	0	1	120



Operations 主要动作参数

Item 项目	Max. single rope lifting speed (empty load) 单绳速度(空载)	Rope diameter/length 钢丝绳直径/长度	Max. single line pull 最大单绳拉力
Main winch 主卷扬	135m/min	18mm/240m	5t
Auxiliary winch 副卷扬	135m/min	18mm/135m	5t
Slewing speed 回转速度	0~2.0r/min		
Full luffing up/down time of boom 主臂起落幅时间	55s/60s		
Full extension/retraction time of boom 主臂伸缩时间	100s/110s		
Outrigger jack 垂直支腿	Extension 伸	25s	
	Retraction 缩	35s	
Outrigger beam 水平支腿	Extension 伸	20s	
	Retraction 缩	20s	

Crane Introduction

整机介绍

Carrier 下车

Driver's cab 驾驶室

- New-gen i-Cab loaded with all new operation system and keyless entry delivers optimal driving comfort. 7" HD LCD instrument, 12.1" super large screen, multi-functional steering wheel and electric A/C are configured. Air suspension driver's seat, double co-driver seats, widened berth and abundant space for storage are provided. The five-in-one multi-functional lock and openable front cover offer more convenience. New suspension system further ensures driving comfort.
- 全新“领致”智能两室,全新操作系统,轿车级极致体验,下车7寸高清液晶组合仪表,12.1寸超大屏,多功能方向盘,无钥匙进入,电动空调,空气悬浮座椅,双人副驾,超宽卧铺,丰富储物空间,整车五锁合一,可开启式前面罩,新一代悬置系统。

Carrier frame 车架

- The anti-torsion box-type structure welded by high-strength steel with strong bearing capacity.
- 三一设计、制造,由细晶粒高强度钢板焊接而成的防扭转箱形结构,承载能力强。

Chassis engine 底盘发动机

- Model: DF Cummins IsLe340 250kW inline six-cylinder diesel engine with watercooler and inter cooler.
- Emission standard: Euro III.
- Fuel reservoir capacity: 400L.
- 型式:东康IsLe340 250kW直列六缸,水冷却、增压中冷、柴油发动机。
- 环保性:排放符合欧三标准。
- 燃料箱有效容积:400L。

Transmission 变速箱

- 10-speed manual transmission with synchronizer, large speed ratio range, adaptable to slope climbing and high-speed traveling.
- 10档手动变速箱带同步器,速比范围大,即可满足低速场地爬坡行驶又可满足高速行驶。

Transmission shaft 传动轴

- Optimized layout, higher torque output via contrate gear connecting transmission shaft cardan.
- 优化的传动轴布置,传动轴传动平稳、可靠。最优优化力传输,采用端面齿联结传动轴,传递扭矩较大。

Axle 车桥

- All-axle steering, axles 3, 4 are drive axles with built-in differential lock, realizing tougher ability to rough-terrain travelling. Press-welding axle housing technology, bearing capacity is stronger.
- 1/2/3/4轴为转向轴,3/4轴为驱动轴,带有轮间和轴间差速,脱困能力强;冲焊桥壳工艺,承载能力更强。

Suspension system 悬挂系统

- The suspension of all axles is realized by independence leaf spring.
- The system's strength is verified by 100,000 cycling fatigue tests, hence ride comfort is out of question.
- 前、后轴采用独立式钢板弹簧。
- 悬挂系统经过超过10万次的疲劳试验,保证强度的同时兼顾乘坐的舒适性。

Steering 转向系统

- Hydro boosted steering system adopts large flow steering gear + steering power cylinder, which can greatly reduce steering resistance and realize easier operation. In the mode of all wheel steering, the steering radius can be reduced to driver's need.
- 液压助力转向,采用大流量转向器+转向助力油缸,大大减小转向阻力,转向更轻便。全轮转向模式,转弯半径更小。

Tires 轮胎

- Nine (including one spare tire) radial vacuum tires sized 385/95R25, strong bearing capacity and durability.
- 9(含1个备胎)一轮胎规格:385/95R25,钢丝真空轮胎,承载能力大,耐用。

Wheel formula 车轮模式

- 8 × 4 × 8.

Outrigger 支腿

- H-type layout, four point support with high strength steel plate, hydraulically telescoping at horizontal and vertical directions. Jack cylinders are protected by two-way hydraulic lockout. Outrigger span 6.4m × 8m.
- Electronic control, support one key leveling function.
- H型支腿4点支撑,纵、横跨距6.4m × 8m,易操作、稳定性强;采用细晶粒高强度钢板材料,全液压横向伸缩。支腿垂直油缸采用双向液压锁进行安全保护。
- 支腿操作电控控制,支持一键调平。

Brake 制动系统

- The braking system includes service brake & parking brake & emergency brake & assisting brake.
- Service brake: air servo, dual circuit; front axle adopts disc brake and dual chambers, delivering stronger braking performance.
- Parking brake: functioning at axles 3 and 4 by spring-loaded air chamber.
- Emergency brake: performed by accumulator releasing pressure.
- Assisting brake: engine exhaust brake and retarder, safety assured when driving down long slopes.
- 制动系统包括行车制动、驻车制动、应急制动和辅助制动。
- 行车制动采用双回路制动系统,所有车轮均用空气间隙制动器,前桥采用盘式制动器+双气室,制动能力更强。
- 驻车制动是通过气室内弹簧作用在第三、四桥上。
- 应急制动阀由蓄能器储能断气制动兼做应急制动。
- 辅助制动为缸内制动+缓速器,保证在下长坡时的制动安全,保证行车的安全可靠。

Electrical system 电气系统

- 2*12V maintenance-free battery with a mechanical power switch, the overall power can be cut off manually. CAN instrument, data integration between superstructure and chassis.
- 2 × 12V免维护蓄电池,配有机械式电源总开关,可手动切断整车电源;总线控制系统,可实现上下车信息交互。

Crane Introduction

整机介绍

Superstructure 上车

Operator's cab 操纵室

- It adopts pressed and welded structure, equipped with safety glass, sun shade, outward opening door, joystick mounted on the control box in line with the principle of man-machine engineering; Corrosion-resistant FRP reinforced structure, fully covered softened interior, panoramic skylight, operator seat back tiltable and other use-friendly design, making it comfortable and easy to operate. Touch screen of adjustable angle of view realizes multi-screen & multi-angle monitoring to ensure working safety and the one-click operation. The main control console is combined with the operation display system for convenient operation. Cooling / heating A/C available.
- 采用冲压成型的全焊接结构, 装有安全玻璃, 车窗装有遮阳帘, 外开式车门, 操纵杆安装在操纵箱上, 符合人机工程原理; 防腐玻璃钢强化复合结构、全覆盖软化内饰、全景式天窗、操作座椅靠背可倾斜定位等人性化设计, 操作舒适、轻松; 触摸式显示屏, 视角可调节、多画面、多角度监控保证作业安全, 满足一键式操作; 主控台与操作显示系统有机结合, 人机交互方便快捷; 配备冷暖空调。

Boom & telescoping system 伸缩系统

- The boom structure adopts high strength steel plate and five U-shaped sections with high stability; Full-extension length of boom is 47.5m, jib length of 16m, lifting height of full-extension boom is 48m, and max. lifting height is 64m; boom telescopes via double cylinders with rope arranger.
- 五节臂, 全伸主臂长47.5m副臂16m, 主臂全伸最大起升高度48m, 带副臂最大起升高度64m。由高强度焊接结构钢制成, U形截面, 双缸+绳排伸缩方式。

Hoist 起升机构

- It adopts variable motor to make the operation speed more efficient.
- Normally closed type winch brake, winch balance valve coupled with exclusive anti-slip tech contribute to smoother hoisting.
- 550kg main hook with 60t max. lifting capacity, 120kg auxiliary hook with 6t max. lifting capacity.
- Main winch wire rope: 18-4V × 39S-5FC-1960-U-zSGB8918-L240m.
- Auxiliary winch wire rope: 18-4V × 39S-5FC-1960-U-zSGB8918-L135m.
- 采用变量马达, 作业速度高效。
- 常闭式卷扬制动器, 卷扬平衡阀与独特的防溜钩技术完美结合, 重物起落平稳。
- 主钩550kg, 最大吊重60t; 副钩120kg, 最大吊载6t。
- 主卷钢丝绳: 钢丝绳18-4V × 39S-5FC-1960-U-zSGB8918-L240m。
- 副卷钢丝绳: 钢丝绳18-4V × 39S-5FC-1960-U-zSGB8918-L135m。

Luffing system 变幅系统

- Passive luffing down with balance system, reducing energy cost yet raising stability.
- Luffing angle: -2°~80°.
- 采用自重落幅系统, 降低能耗, 提高落幅操作的平稳性。
- 变幅角度: -2°~80°。

Slewing 回转系统

- 360° slewing and max. slewing speed 2.0r/min, hydraulic proportional speed regulation. Unique slewing buffer design makes the braking more stable.
- 360° 回转最大回转速度2.0r/min, 采用电控比例调速控制, 动作稳定, 系统可靠; 独特的回转缓冲设计, 制动更平稳。

Hydraulics 液压系统

- High quality oil pump, motor, valve and other key hydraulic components, to ensure the stability and reliability of the hydraulic system. The main valve functions flow compensation and load feedback control to easily realize stable control of single action and combined actions under various working conditions.
- The winch adopts high quality motor to make the operation more reliable; The max. speed of main and auxiliary single rope lifting speed is ≥135m/min. The electronic control variable slewing system is adopted to make the slewing start & control more stable and the inching performance more excellent.
- It adopts the load-sensing variable piston pump to adjust the displacement in real time, realizing high-precision flow control, and greatly reducing energy loss.
- New shared double pump intelligent flow distribution system, can adopt independent luffing to avoid the interference of other operations, greatly improved combined action control. At the same time, the valve compensation technology is adopted, so that the flow can be distributed according to demand, which can improve the inching performance and control performance to meet precise lifting.
- Power management: new power matching and power control system with five-gear power, can realize energy saving and noise reduction.
- Dynamically compensated passive luffing down: Active luffing down at large elevation, and passive luffing down at small elevation. This technology can automatically limit the speed to ensure constant speed and smoothness.
- The slewing system comes with an integrated slewing buffer valve and free swing mechanism, featuring smooth start and excellent inching-movement.
- 采用稳定、高品质的主油泵、主阀、卷扬马达、回转马达、平衡阀等关键液压件, 系统可靠性高; 通过精确的参数匹配, 操控性能优越主阀具备流量补偿、负载反馈控制功能, 能在各种工况下, 轻松实现单个动作和组合动作的稳定控制。
- 卷扬采用高品质马达, 作业可靠; 主副卷扬单绳最大速度达 ≥135m/min。采用电控变量回转系统, 回转启动和控制更为平稳, 微动性更卓越。
- 负载敏感系统: 采用大流量双联变量柱塞泵, 流量充足但无浪费, 作业高效、节能环保。
- 智能流量分配: 使用全新智能流量分配主阀, 组合动作时变幅独立, 不受其他动作干扰, 大幅提升组合动作操控性。采用阀后补偿技术, 流量按需分配, 微动性和操控性卓越, 满足各种精准吊装。
- 功率管理: 全新动力匹配及功率控制, 5挡取力, 节能降噪。
- 动态补偿自重落幅技术: 大仰角时加压落幅, 小仰角时自重落幅, 采用流量补偿技术可自动限速, 保证落幅匀速平稳。
- 集成回转缓冲控制: 融合升压缓冲、顺序制动及自由滑转技术, 回转启停柔和平稳。

Crane Introduction

整机介绍

Counterweight 配重

- Fixed counterweight 2.8t, movable counterweight 4.5t + 4.5t.
- 固定配重2.8t,活动配重4.5t + 4.5t。

Control system 控制系统

- High-precision LMI display offers multi-dimensional and all-round safety guarantee.
- Controllers, displays, meters, I/O modules, sensors, etc. are integrated in CAN Bus networking, fast-responsive and intelligent.
- Smart controllers, BCM control modules, fault self-diagnosis system, care free when operating.
- Specialized battery pack, achieving intelligent distribution and control of vehicle power.
- ROOTCLOUD, intelligent monitoring of the machine's movement trajectory and working conditions, functioning statistical analysis and big data management.
- 高精度力矩显示,多维度安全检测,全方位安全保障。
- 控制器、显示器、仪表、I/O模块、传感器等采用CAN总线组网,高速智能。
- 智能控制器,BCM控制模块、故障自诊断系统,作业更省心。
- 专用电瓶仓,整车电量智能分配和控制。
- 树根互联,智能监控主机运动轨迹、吊载工况,统计分析及大数据管理。

Safety equipment 安全装置

- Load moment indicator: Based on the loading mechanics model, the LMI system is established in the method of analytical mechanics. Through online empty-load calibration, the rated hoisting accuracy can reach $\pm 3\%$ to fully protect the hoisting operation.
- The hydraulic system is equipped with hydraulic balance valve, overflow valve, two-way hydraulic lock, etc. to realize the stability and reliability of the hydraulic system.
- The main and auxiliary hoists are equipped with 3rd wrap indicator to prevent over-hoist-down of the wire rope.
- Boom head and jib head are equipped with A2B limit switch to prevent the wire rope from over winding.
- The length & angle sensor and pressure sensor are equipped to display the operating status of the crane in real time, automatically cut off dangerous actions, and give a buzzer alarm.
- 力矩限制器:采用分析力学方法,建立了基于吊重力学模型的力矩限制器计算系统,通过在线空载标定,额定吊重精度达到 $\pm 3\%$,全方位保护吊载作业;超载作业时,系统自动报警提示,为操纵作业提供安全保障。
- 液压系统配置液压平衡阀、溢流阀、双向液压锁等元件,实现液压系统稳定可靠。
- 主、副卷扬配置三圈保护器,防止钢丝绳过放。
- 主、副臂臂端配置高度限位器,防止钢丝绳过卷。
- 配置长度角度传感器、压力传感器,实时显示起重机作业状态,自动切断危险动作,蜂鸣报警。

Operating Range

起升高度曲线

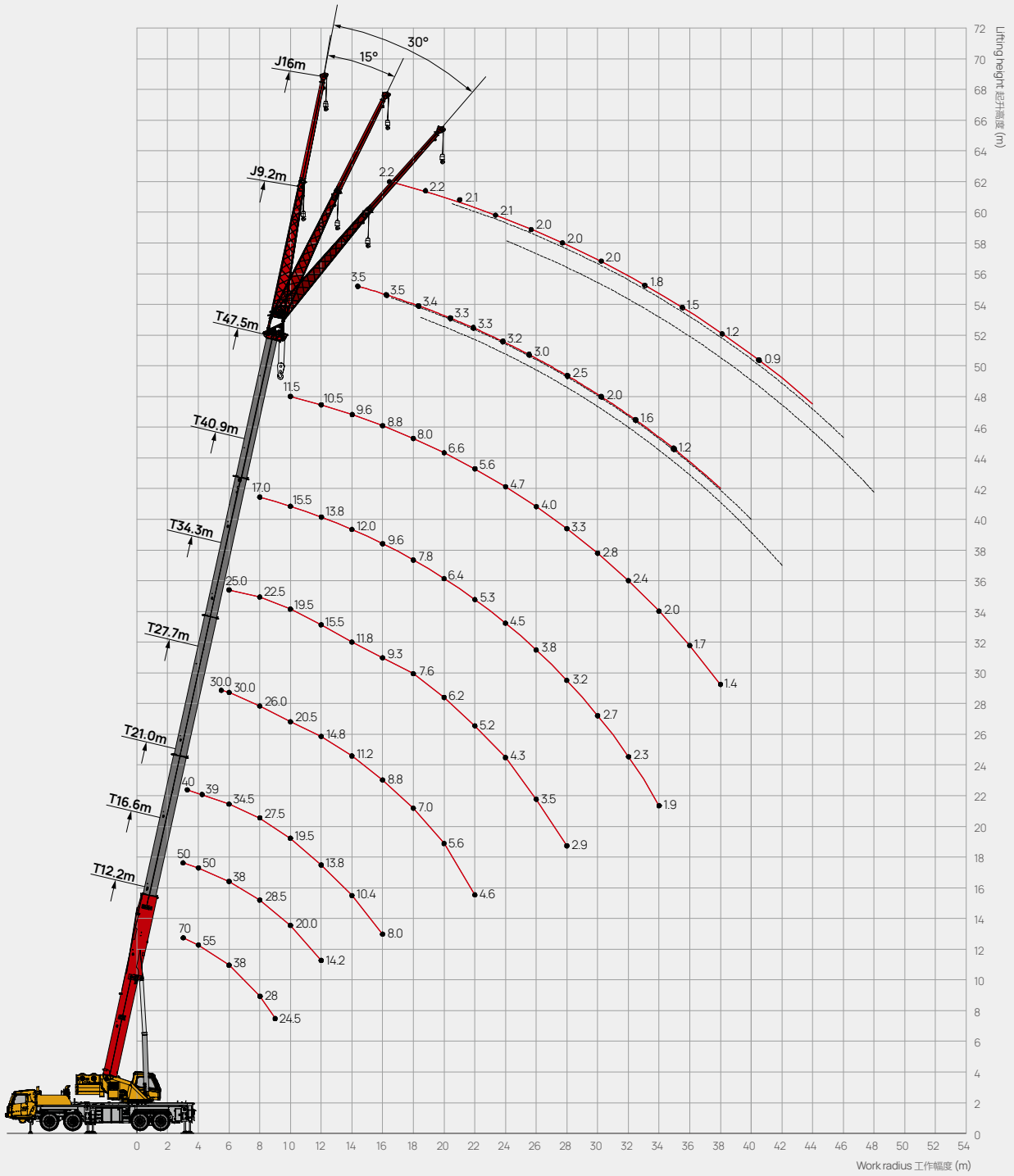







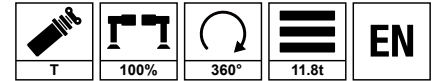

Load Chart - Telescopic Boom

性能表 - 主臂

Unit: kg



	12.2	16.6	21.0	27.7	34.3	40.9	47.5	18.8	25.5	32.1	38.7	23.2	29.9	36.5	43.1	
3	*70000															3
3.5	60000	50000	40000					30000								3.5
4	55000	50000	39000					30000	28000			30000				4
4.5	51000	47500	39000	30000				30000	28000			30000				4.5
5	47000	45000	38000	30000				30000	28000			30000	26500			5
5.5	42000	41000	35500	30000				30000	28000	19000		30000	26500			5.5
6	38000	38000	34500	29000	25000			30000	27500	19000		30000	26000			6
7	32000	32000	31000	28000	24000	17000		30000	26500	18000	14000	30000	25000	18000		7
8	28000	28500	27500	26000	22500	17000		28000	24500	17000	13000	27000	24000	17500	12500	8
9	24500	24300	24000	23500	21000	16500	11500	24500	22500	16000	12500	24500	22000	16500	12500	9
10		20000	19500	20500	19500	15500	11500	21700	21000	15000	12000	21000	21300	15500	12000	10
11		16700	16200	17300	17500	14500	11200	18400	18800	14000	11500	17800	18200	14500	11200	11
12		14200	13800	14800	15500	13800	10500	15800	16300	13000	11000	15300	15700	14000	10800	12
14			10400	11200	11800	12000	9600	12100	12700	11500	10000	11700	12100	12400	9700	14
16			8000	8800	9300	9600	8800		10200	10000	9200	9200	9600	9900	9100	16
18				7000	7600	7800	8000		8400	8500	8400	7400	7700	8100	8400	18
20				5600	6200	6400	6600		7000	7100	7300		6300	6700	7000	20
22				4600	5200	5300	5600			6000	6200		5200	5600	5800	22
24					4300	4500	4700			5100	5300		4300	4700	4900	24
26					3500	3800	4000			4400	4600			4000	4200	26
28					2900	3200	3300				4000			3400	3600	28
30						2700	2800				3500			2900	3100	30
32						2300	2400				3000				2600	32
34						1900	2000								2200	34
36							1700								1900	36
38							1400									38
40																40
	12(*14)	10	8	6	5	4	3	6	6	4	3	6	6	4	3	
	0	50	100	100	100	100	100	0	0	0	0	50	50	50	50	
	0	0	0	25	50	75	100	25	50	75	100	25	50	75	100	









Remark: * Need additional device.
备注: * 代表需要借助辅助装置。

Load Chart - Telescopic Boom

性能表 - 主臂



Unit: kg

	12.2	16.6	21.0	27.7	34.3	40.9	47.5	18.8	25.5	32.1	38.7	23.2	29.9	36.5	43.1	
3	*70000															3
3.5	60000	50000	40000					30000								3.5
4	55000	50000	39000					30000	28000			30000				4
4.5	50500	47000	39000	30000				30000	28000			30000				4.5
5	46000	44000	38000	30000				30000	28000			30000	26500			5
5.5	41500	40500	35500	30000				30000	28000	19000		30000	26500			5.5
6	37500	37500	34500	29000	25000			30000	27500	19000		30000	26000			6
7	32000	31000	31000	28000	24000	17000		30000	26500	18000	14000	30000	25000	18000		7
8	26500	25800	25500	26000	22500	17000		28000	24500	17000	13000	27000	24000	17500	12500	8
9	21200	20500	20000	21200	21000	16500	11500	22500	22500	16000	12500	21500	22000	16500	12500	9
10		16700	16200	17200	17700	15500	11500	18500	19000	15000	12000	17700	18100	15500	12000	10
11		14000	13400	14200	14800	14500	11200	15600	16200	14000	11500	14800	15500	14500	11200	11
12		11800	11200	12000	12700	13000	10500	13400	14000	13000	11000	12500	13200	13200	10800	12
14			8200	9000	9600	10000	9600	10200	10800	10800	10000	9400	10100	10100	9700	14
16			6000	7000	7400	7900	8100		8600	8600	8800	7400	7900	8100	8300	16
18				5400	5900	6300	6500		7000	7100	7200	5800	6300	6500	6700	18
20				4200	4700	5100	5300		5700	5800	6000		5100	5300	5500	20
22				3300	3800	4200	4400			4800	5000		4100	4400	4600	22
24					3000	3400	3600			4000	4200		3300	3600	3800	24
26					2400	2800	3000			3400	3600			3000	3200	26
28					1900	2300	2500				3100			2500	2700	28
30						1900	2000				2600			2000	2200	30
32						1500	1600				2200				1800	32
34						1200	1300								1500	34
36							1000								1200	36
38																38
40																40
	12(*14)	10	8	6	5	4	3	6	6	4	3	6	6	4	3	
	0	50	100	100	100	100	100	0	0	0	0	50	50	50	50	
	0	0	0	25	50	75	100	25	50	75	100	25	50	75	100	









Remark: * Need additional device.
备注: * 代表需要借助辅助装置。

Load Chart - Telescopic Boom

性能表 - 主臂

Unit: kg



	12.2	16.6	21.0	27.7	34.3	40.9	47.5	18.8	25.5	32.1	38.7	23.2	29.9	36.5	43.1	
3	*70000															3
3.5	60000	50000	40000					30000								3.5
4	54000	50000	39000					30000	28000			30000				4
4.5	49000	47000	39000	30000				30000	28000			30000				4.5
5	45000	44000	38000	30000				30000	28000			30000	26500			5
5.5	40000	39500	35500	30000				30000	28000	19000		30000	26500			5.5
6	36500	35500	34500	29000	25000			30000	27500	19000		30000	26000			6
7	29800	29000	28000	28000	24000	17000		30000	26500	18000	14000	30000	25000	18000		7
8	22500	21500	21000	22300	22500	17000		23700	24000	17000	13000	23000	23500	17500	12500	8
9	17800	17000	16300	17500	18000	16500	11500	19000	19500	16000	12500	18000	18800	16500	12500	9
10		13700	13100	14100	15000	15000	11500	15500	16200	15000	12000	14800	15400	15500	12000	10
11		11300	10700	11800	12500	12600	11200	13000	13500	13600	11500	12300	12900	13000	11200	11
12		9400	8800	9800	10500	10800	10500	11000	11600	11700	11000	10400	11000	11200	10800	12
14			6100	7000	7700	8000	8400	8200	8700	8900	9100	7500	8100	8500	8600	14
16			4300	5200	5800	6200	6400		6700	6900	7000	5600	6100	6500	6700	16
18				3900	4400	4800	5000		5300	5500	5600	4300	4700	5100	5300	18
20				3000	3400	3800	4000		4300	4500	4600		3700	4000	4300	20
22				2200	2600	2900	3200			3600	3800		2900	3200	3500	22
24					2000	2300	2500			2900	3100		2300	2500	2800	24
26					1500	1800	1900			2400	2600			2000	2300	26
28					1100	1400	1500				2100			1500	1800	28
30						1000	1100				1700			1200	1400	30
32															1100	32
34																34
36																36
38																38
40																40
	12(*14)	10	8	6	5	4	3	6	6	4	3	6	6	4	3	
	0	50	100	100	100	100	100	0	0	0	0	50	50	50	50	
	0	0	0	25	50	75	100	25	50	75	100	25	50	75	100	



Remark: * Need additional device.
备注: * 代表需要借助辅助装置。

Load Chart-Fixed Jib

性能表 - 副臂

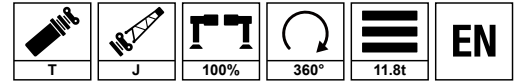
Unit: kg



	47.5m+9.2m			47.5m+16m			
	0°	15°	30°	0°	15°	30°	
78	3500	3300	2500	2200	2000	1400	78
77	3500	3200	2500	2200	1900	1350	77
75	3400	3100	2500	2100	1800	1300	75
74	3400	3050	2400	2100	1700	1250	74
73	3300	3000	2400	2100	1600	1200	73
70	3300	2800	2300	2000	1500	1200	70
67	3200	2600	2100	2000	1400	1150	67
64	3000	2500	2000	2000	1300	1100	64
61	2500	2100	1800	1800	1200	1000	61
58	2000	1700	1500	1500	1000	950	58
55	1600	1300	1100	1200	950	850	55
51	1200	1050	950	900	800	700	51

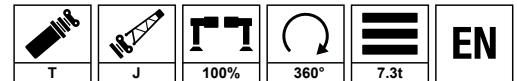



	47.5m+9.2m			47.5m+16m			
	0°	15°	30°	0°	15°	30°	
78	3500	3300	2500	2200	2000	1400	78
77	3500	3200	2500	2200	1900	1350	77
75	3400	3100	2500	2100	1800	1300	75
74	3400	3050	2400	2100	1700	1200	74
73	3300	3000	2400	2100	1600	1200	73
70	3300	2800	2300	2000	1500	1150	70
67	3100	2600	2100	2000	1400	1100	67
64	2400	2000	1700	1800	1300	1050	64
61	1800	1600	1400	1400	1100	950	61
58	1400	1250	1100	1100	900	850	58
55	1100	950	900	850	700	650	55
51	700	650	600	600	550	500	51

Load Chart-Fixed Jib

性能表 - 副臂

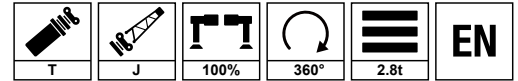
Unit: kg



	47.5m+9.2m			47.5m+16m			
	0°	15°	30°	0°	15°	30°	
78	3500	3300	2500	2200	2000	1400	78
77	3500	3200	2500	2200	1900	1350	77
75	3400	3100	2500	2100	1800	1300	75
74	3400	3050	2400	2100	1700	1200	74
73	3300	3000	2400	2100	1600	1200	73
70	3200	2700	2300	2000	1450	1150	70
67	2400	1900	1700	1800	1350	1050	67
64	1500	1400	1300	1300	1050	950	64
61	1100	1000	950	1000	800	750	61
58	800	750	700	700	600	550	58
55	600	450	400	400			55

Remark:

- Value listed are the max. capacity when the crane is in a level condition on solid ground or surface.
- Radius refers to actual radius with boom deflection considered.
- Value above are calculated with hooks and lifting slings considered (550kg main hook block, 120kg aux. hook block).
- When the fifth outrigger is landed in position, value listed are applicable for 360 degree operation.
- Rated lifting performance on boom point sheave equals 5000kg; boom load capacity shall be 2300kg less than value given when jib unfolds.
- Load value is given according to the larger radius or boom length value when the actual radius or boom length falls between two numbers above.

备注:

- 起重性能表中给定数值是在平整坚固的地面上，整机调平状态下起重机的额定起重量。
- 起重性能表中工作幅度是指吊载后的实际幅度。
- 起重性能表中额定起重量包括起重钩（主起重钩重 550kg，副起重钩重 120kg）和吊具的重量。
- 打开好第五支腿时，表中数值适用于全方位（360°）作业。
- 使用臂尖滑轮时额定起重量不超过 5000kg。若副起重臂处于展开状态，主臂起吊的额定起重量应减少 2300kg。
- 如果实际臂长和幅度介于两个数值之间时，取较长的臂长及较大的幅度所决定的额定起重量进行起吊作业。



SANY GROUP CRANE BU

SANY Mobile Crane Industrial Park, No.168 Jinzhou Avenue, Jinzhou Development Zone, Changsha City,
Hunan Province, P.R. China Zip 410600
Consulting sanycrane@sanygroup.com (Crane BU) / crd@sany.com.cn (IHQ)
After-sales Service 0086-400 6098 318

Reminder:

Any change in the technical parameters and configuration due to product modification or upgrade may occur without prior notice.
The machine in the picture may include additional equipment. This brochure is for reference only, and goods in kind shall prevail.
Copyright at SANY. No part of this brochure may be copied or used for any purpose without written approval from SANY.

© Edited in August 2023

三一集团起重事业部

中国湖南长沙金洲开发区金洲大道 168 号 三一汽车起重机产业园 邮编: 410600
咨询: sanycrane@sanygroup.com (起重事业部) / crd@sany.com.cn (国际总部)
海外售后服务: 0086-400 6098 318

温馨提示:

由于技术不断更新, 技术参数及配置如有更改, 恕不另行通知。图中机器可能包括附加设备, 本画册仅供参考, 以实物为准。
版权为三一所有, 未经三一书面许可, 本画册任何内容不得被复制用于任何目的。

© 2023 年 8 月版

